

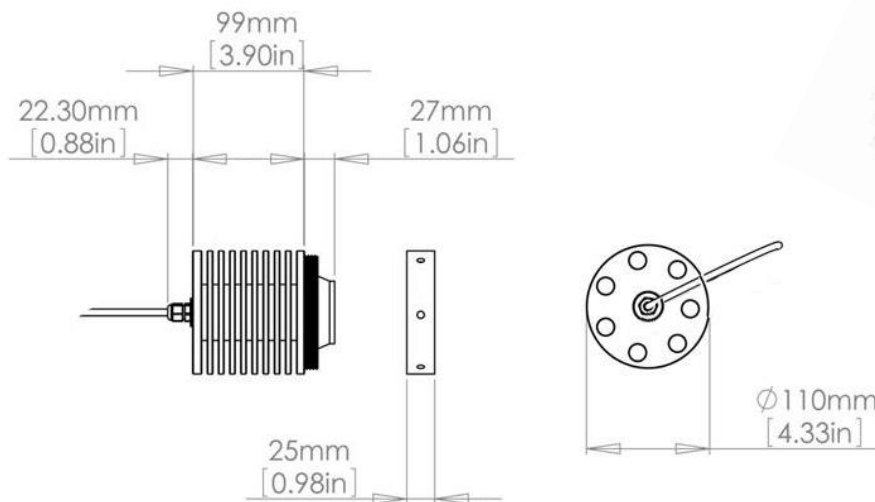

SUPRA SY Series - Dual Color TRX802

SY RETROFIT UNDERWATER LED LIGHT
(FOR UPGRADE OF HID OR OTHER LED THROUGH HULL UNDERWATER LED LIGHTING SYSTEMS)

PART DESCRIPTION	SUPRA DUAL COLOR TRX802 SY RETROFIT UNDERWATER LED LIGHT
Part Number	Master Light (1 per system) - 60-0257 Secondary Light - 60-0258
Available Colors	Dual Color (Blue & White)
Lumens	18,000
Fixture Lumens (White)	8,000
Number & Type Of LED	White - 36 x 10W, Blue - 48 x 3W
LED Power - HICOB Array	Yes
Typical LED Life	50,000+ Hours
Warranty	3 Years
User Control Options	On/Off Switch (Third party supplied)
User Control Options - Enhanced	Lumi-Switch (Lumishore Smart Switch)
Lights Synchronized (All Lights, All Modes, All Colors)	Yes



SUPRA SY Series - Dual Color

TRX802



SY RETROFIT UNDERWATER LED LIGHT
(FOR UPGRADE OF HID OR OTHER LED THROUGH HULL UNDERWATER LED LIGHTING SYSTEMS)

TECHNICAL	
Driver	Multi-Channel External Driver
Supply Voltage Range	90 - 250 V AC (12 or 24 V DC option also available)
Max Current Draw (AC)	0.6 A
Surge Protection	Yes (3,000V)
ATRB (Automatic Thermal Roll-Back)	Yes
Low Voltage Protection	Automatic Voltage Roll-Back Control, and Low Voltage Cut-Out
Auto Power Control	Yes - Intelligent Multi-Channel Power Management
“Soft Start” Electronics Protection	Yes
Reverse Polarity Protection	Yes
In Rush Current Protection	Yes
Power Line Noise Suppression	Yes
System Memory	Yes (Switches on at last setting)
Light Synchronization	Yes - All lights, All Modes

PHYSICAL	
Beam Angle	110°
Water Ingress Protection Rating	IP68
Light Diameter	110mm (4.33")
Shaft Length	99mm (3.90")
Construction	Light Body: Anodized Aluminum (5083), Adaptor Ring: Stainless Steel (316L)
Light Cable Length	3m (9'8") Standard

LIGHTING SYSTEM FUNCTIONALITY (ON/OFF SWITCH)	
White	Yes
Blue	Yes
Color Fade Cycle	Yes
White Strobe (Fixed Frequency)	Yes
Blue Strobe (Fixed Frequency)	Yes

LIGHTING SYSTEM FUNCTIONALITY (LUMI-SWITCH)		
Mode	On/Off	Momentary
White	Yes	No Action
Blue	Yes	No Action
Color Fade Cycle	Yes	Brightness Control (Pause Cycle)
White Strobe (Fixed Frequency)	Yes	Change Strobe Speed
Blue Strobe (Fixed Frequency)	Yes	Change Strobe Speed

ACCESSORIES	PART NUMBER
Lumi-Switch (Smart Switch)	60-0202
THX / TIX Supra Lumi-Hub	60-0252